

TECHNICAL SHEET

17.45 FULL ELECTRIC

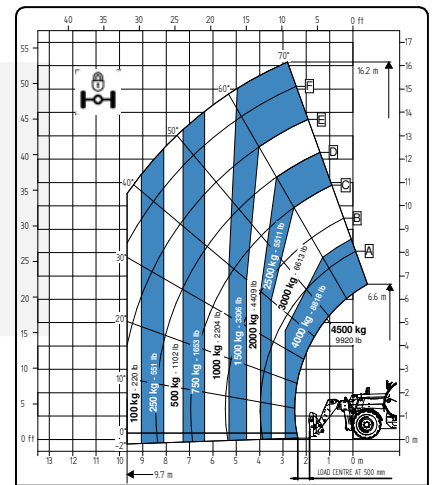

It brings to the attention of all potential customers, all recipients, and to the maximum extent possible, external interlocutors, that Faresin Industries S.p.A. adopts a general Disclaimer regarding the description of the technical and functional characteristics of its machineries, as well as the manner of their use, also with regard to their safety. The Disclaimer must be understood as having a general scope, and therefore Faresin Industries s.p.a. invites to know it, also by accessing the website: www.faresindustries.com

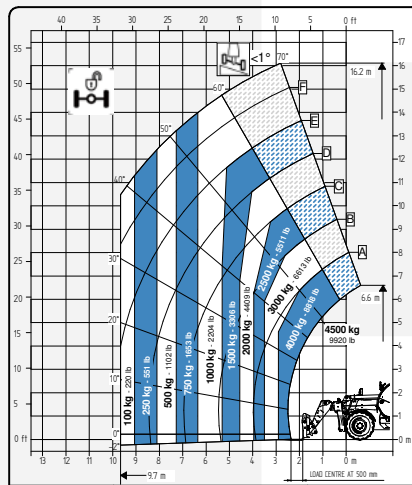
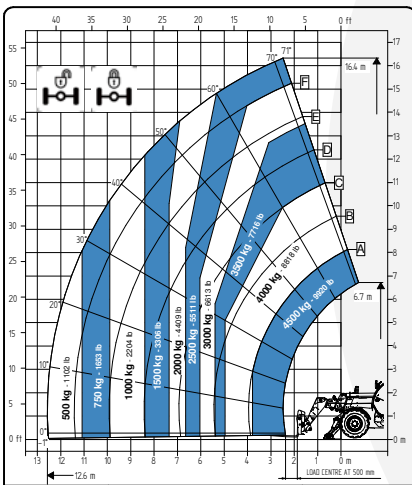

FARESIN.COM



17.45 FULL ELECTRIC

TECHNICAL FEATURES























MODELS		17.45E
DIMENSIONS		
Height	mm	2560
Width	mm	2360
Length	mm	6520
Cabin width	mm	960
WEIGHT		
Weight	kg	12100
DETAILS		
Number of extracting sections	nr	3
Max capacity	kg	4500
Max lifting height	m	16,4
Max horizontal boom extension	m	12,6
Boom extension at max height	m	2,5
Swinging Angle	°	144
TANK CAPACITY		
Hydraulic oil tank	l	150
CONNECTION FOR EQUIPMENT		
FH		●
TYRES		
405/70 20		○
405/70 24		○
445/65 R22.5		●
Turning radius	m	4
BATTERIES AND CHARGERS		
Battery		435V (105 Ah)
Charging type	v	220 - 380 

NOTE: All dimensions defined on model with wheels 405/70 20

CONFIGURATIONS		FULL ELECTRIC
TRANSMISSION		
Transmission		electric
Speed	km/h	25
MOTOR		
Transmission	kW	51 (S1)
Hydraulic services	kW	23 (S1)
HYDRAULIC		
Pump type		gears pump
Hydraulic capacity	l/bar	120/250
Distribution		flow sharing
OTHER		
Joystick		hydraulic-electro proportional
Cabin		Queen Cab
Quick coupling		○
Front and rear LED lights		○
Floating boom		○
Boom suspension		○
Manual 6-way diverter		○
PEB (Boom Electric Socket)		○
Front constant flow		○
Bucket mode		●
SPECIAL FEATURES		
Air conditioning		○
Forward buzzer avas		○
Farmatics		FULL (2-5 years)

● Standard ○ Optional - Not available

POWER AND BATTERY CAPACITY	45 kW/h (105 Ah)
AUTONOMY STANDARD CYCLE INTENSIVE (eco mode)	UP TO 3,5 HOURS
AUTONOMY STANDARD CYCLE NOT INTENSIVE (eco mode)	UP TO 8 HOURS

CHARGERS		
STANDARD ON BOARD MONO PHASE CHARGER 11 KW	20-80%	5 h
POWER INPUT  32 A  220 VAC		
POWER OUTPUT  14 A  435 VDC	0-100%	8 h
STANDARD THREE-PHASE CHARGER ON BOARD 11 KW	20-80%	3 h
POWER INPUT  16/32 A  400 VAC		
POWER OUTPUT  22 A  435 VDC	0-100%	5 h 30 m
OPTIONAL SINGLE-PHASE CHARGER ON BOARD 22 KW	20-80%	12 h
POWER INPUT  16 A  220 VAC		
POWER OUTPUT  4 A  435 VDC	0-100%	27 h
OPTIONAL THREE-PHASE 16A CHARGER ON BOARD 22 KW	20-80%	3 h
POWER INPUT  16 A  400 VAC		
POWER OUTPUT  22 A  435 VDC	0-100%	5 h 30 m
OPTIONAL THREE-PHASE 32A CHARGER ON BOARD 22 KW	20-80%	2 h
POWER INPUT  32 A  400 VAC		
POWER OUTPUT  37 A  435 VDC	0-100%	3 h 30 m
50KW DC CHARGING STATION	20-80%	1 h 30 m
POWER INPUT  50 Kw		
POWER OUTPUT  50 A (variables)	0-100%	2 h 30 m