

# FS 10.40 MIDDLE

TECHNICAL SHEET



# FS 10.40 MIDDLE

## TECHNICAL FEATURES

| Models                        | 10.40 |      |
|-------------------------------|-------|------|
| <b>Dimensions</b>             |       |      |
| [A] Height                    | mm    | 2450 |
| [B] Width                     | mm    | 2310 |
| [C] Track                     | mm    | 1862 |
| [D] Ground clearance          | mm    | 350  |
| [E] Front overhang            | mm    | 1390 |
| [F] Pitch                     | mm    | 2950 |
| [G] Rear overhang             | mm    | 804  |
| [H] Length without tow hook   | mm    | 5144 |
| [I] Length with tow hook      | mm    | 5305 |
| [L] Cab width                 | mm    | 960  |
| Width with stabilizers        | mm    | -    |
| <b>Loading system</b>         |       |      |
| Lifting capacity              | kg    | 4000 |
| Lifting height                | m     | 9,9  |
| Max horizontal boom extension | m     | 6,6  |
| Boom extension at max height  | m     | 1,2  |
| Number of extracting sections | n.    | 2    |
| Swinging Angle                | °     | 144  |
| <b>Tank capacity</b>          |       |      |
| Fuel tank                     | l     | 120  |
| Adblue tank                   | l     | 10   |
| Hydraulic oil tank            | l     | 120  |
| <b>Connection equipment</b>   |       |      |
| Fh                            |       | ●    |
| FH Heavy                      |       | -    |
| Euro                          |       | -    |
| <b>Other</b>                  |       |      |
| Telematics farmatics          |       | ○    |
| Frame lateral levelling 10°   |       | -    |
| Front stabilizers             |       | -    |
| Rear axle swing block         |       | -    |
| Bucket mode                   |       | ●    |

● Standard    ○ Optional    - Not available

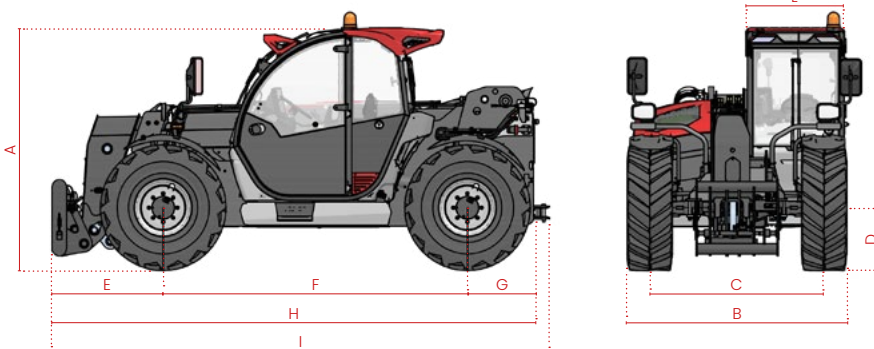

| Models                        | 10.40 |       |
|-------------------------------|-------|-------|
| <b>Maximum unladen weight</b> |       |       |
| Classic 55                    | kg    | 8.950 |
| Classic 75                    | kg    | 9.050 |
| Dynamic 85                    | kg    | 9.050 |
| Performance 85                | kg    | 9.050 |
| Excellence 85                 | kg    | 9.100 |
| Excellence HVTronic 100       | kg    | 9.210 |

| Models                  | 10.40 |        |
|-------------------------|-------|--------|
| <b>Drawbar pull</b>     |       |        |
| Classic 55              | daN   | 5.800  |
| Classic 75              | daN   | 5.800  |
| Dynamic 85              | daN   | 5.800  |
| Performance 85          | daN   | 6.780  |
| Excellence 85           | daN   | 6.780  |
| Excellence HVTronic 100 | daN   | 10.000 |

| Models                          | 10.40 |      |
|---------------------------------|-------|------|
| <b>Tyres</b>                    |       |      |
| Turning radius                  | m     | 4,15 |
| 400/70 - 20"                    |       | ●    |
| 400/70 - 24"                    |       | ○*   |
| 460/70-R24" LIFT PRO OFFSET +29 |       | ○    |
| 460/70-R24" XMCL OFFSET +29     |       | ○    |
| 18 - 19.5 MPT-06 OFFSET +40     |       | ○    |

\* Standard for the Performance, Excellence and Excellence HVTronic configurations.

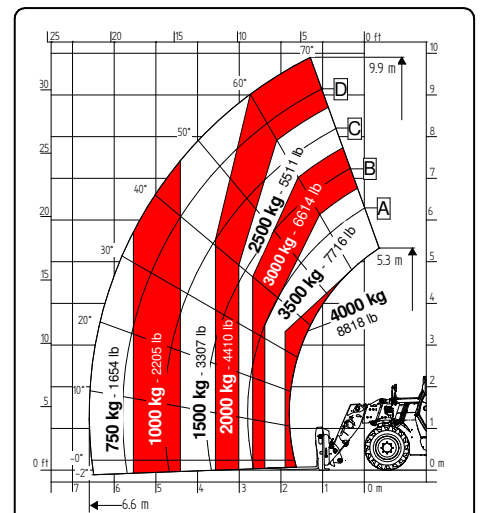

10.40

| Configurations   |  | Classic 55   | Classic 75    | Dynamic 85    | Performance 85            | Excellence 85             | Excellence HVTronic 100   |
|--|--|--|---------------|---------------|---------------------------|---------------------------|---------------------------|
| <b>Engine</b>  |  |  |               |               |                           |                           |                           |
| Deutz 55,4/75  | <span>STAGE V</span> kW/hp                         | ●  | -             | -             | -                         | -                         | -                         |
| Deutz 75/102   | <span>STAGE IIIA</span> <span>STAGE V</span> kW/hp | -  | ●             | -             | -                         | -                         | -                         |
| Deutz 85/115   | <span>STAGE IIIA</span> <span>STAGE V</span> kW/hp | -  | -             | ●             | ●                         | ●                         | -                         |
| Deutz 100/136  | <span>STAGE V</span> kW/hp                         | -  | -             | -             | -                         | ○                         | ●                         |
| Engine water preheating                                |  | ○  | ○             | ○             | ○                         | ○                         | ○                         |
| Post-treatment system                                  |  | DOC/DPF  | DOC/DPF + SCR | DOC/DPF + SCR | DOC/DPF + SCR             | DOC/DPF + SCR             | DOC/DPF + SCR             |
| Radiator fan   |  | Proportional   | Proportional  | Proportional  | Proportional + Reversible | Proportional + Reversible | Proportional + Reversible |
| <b>Hydraulics</b>                                      |  |  |               |               |                           |                           |                           |
| pump type  |  | Gears  | Gears         | Gears         | LS piston                 | LS piston                 | LS piston                 |
| Hydraulic flow-rate                                    | l/bar  | 100/250  | 100/250       | 120/250       | 150/250                   | 170/250                   | 170/250                   |
| Flow sharing distributor                               |  | ●  | ●             | ●             | ●                         | ●                         | ●                         |
| Electro-proportional joystick                          |  | Hydraulic  | Hydraulic     | Hydraulic     | Hydraulic                 | CAN-BUS                   | CAN-BUS                   |
| Quick release  |  | ○  | ○             | ○             | ○                         | ●                         | ●                         |
| Boom suspension  |  | ○  | ○             | ○             | ○                         | ○                         | ○                         |
| Floating boom  |  | ○  | ○             | ○             | ○                         | ●                         | ●                         |
| Lifting valve  |  | -  | -             | -             | Ecofast                   | Ecofast-E                 | Ecofast-E                 |
| Manual 6-way diverter valve                            |  | ○  | ○             | ○             | ○                         | ●                         | ●                         |
| Constant front flow                                    |  | ●  | ●             | ●             | ●                         | ●                         | ●                         |
| Creeper  |  | ●  | ●             | ●             | ●                         | ●                         | ●                         |
| Boom Electric Socket (PEB)                             |  | ○  | ○             | ○             | ○                         | ○                         | ○                         |
| <b>Boom function</b>                                   |  |  |               |               |                           |                           |                           |
| Height limiter   |  | -  | -             | -             | -                         | ●                         | ●                         |
| Electronic boom speed control                          |  | Full BSC   | Full BSC      | Full BSC      | Full BSC                  | Full + Single BSC         | Full + Single BSC         |
| Autoretract  |  | -  | -             | -             | -                         | ●                         | ●                         |
| Controlled boom retraction                             |  | ●  | ●             | ●             | ●                         | ●                         | ●                         |
| Bucket shaking   |  | -  | -             | -             | -                         | ●                         | ●                         |
| <b>Transmission</b>                                    |  |  |               |               |                           |                           |                           |
| Hydrostatic single gear 25 km/h                        |  | ●  | -             | -             | -                         | -                         | -                         |
| Hydrostatic single gear 30 km/h                        |  | ●  | ●             | ●             | -                         | -                         | -                         |
| Hydrostatic two mechanical gears 40 km/h               |  | -  | -             | -             | ●                         | ●                         | -                         |
| Hydrostatic continuous variation 40 km/h               |  | -  | -             | -             | -                         | -                         | ●                         |
| <b>Axles</b>   |  |  |               |               |                           |                           |                           |
| 45% limited slip self-locking differential front axles |  | ●  | ●             | ●             | ●                         | ●                         | ●                         |
| Open type differential rear axles                      |  | ●  | ●             | ●             | ●                         | ●                         | ●                         |
| 100% differential lock rear axles                      |  | -  | -             | -             | -                         | -                         | -                         |
| <b>Brakes</b>  |  |  |               |               |                           |                           |                           |
| Service brake  |  | Multi-disc in oil bath                               |               |               |                           |                           |                           |
| Parking brake  |  | Multi-disc in oil bath with negative drive type SAHR |               |               |                           |                           |                           |
| Pneumatic / hydraulic trailer brake                    |  | -  | -             | ○             | ○                         | ○                         | ○                         |
| <b>Lights</b>  |  |  |               |               |                           |                           |                           |
| LED front lights                                       |  | ○  | ○             | ○             | ○                         | ●                         | ●                         |
| LED rear lights  |  | ●  | ●             | ●             | ●                         | ●                         | ●                         |
| LED front and rear work lights                         |  | ○  | ○             | ○             | ●                         | ●                         | ●                         |
| LED boom work lights                                   |  | ○  | ○             | ○             | ○                         | ○                         | ○                         |
| Step courtesy light                                    |  | ○  | ○             | ○             | ●                         | ●                         | ●                         |
| Trailer lights rear socket                             |  | ○  | ○             | ●             | ●                         | ●                         | ●                         |
| <b>Cabin</b>   |  |  |               |               |                           |                           |                           |
| Cabin  |  | Standard   | Standard      | Standard      | Standard                  | Comfort Plus              | Comfort Plus              |
| Protection grille for windscreen                       |  | ○  | ○             | ○             | ○                         | ○                         | ○                         |
| Touch colour display                                   | "  | 5  | 5             | 5             | 5                         | 7                         | 7                         |
| Start and stop system                                  |  | ●  | ●             | ●             | ●                         | ●                         | ●                         |
| Internal rear-view mirror                              |  | ○  | ○             | ○             | ●                         | ●                         | ●                         |
| Air conditioning                                       |  | ○  | ○             | ○             | ○                         | ●                         | ●                         |
| <b>Other</b>   |  |  |               |               |                           |                           |                           |
| Tow hook   |  | ○  | ○             | ●             | ●                         | ●                         | ●                         |

# TELEHANDLERS **NEXT GENERATION**



**FARESIN INDUSTRIES SPA  
HEADQUARTERS**

Via dell'Artigianato, 36  
36042 Breganze (Vicenza), Italy  
Tel. + 39 0445 800300  
faresin@faresin.com

**FARESIN DEUTSCHLAND GMBH**

Steinach B.R. - an der  
Frankenhoehe 1  
91605 Gallmersgarten, Germany  
Tel. +49 9843 9802828  
lager@faresin.de

**FARESIN DEUTSCHLAND  
NORD GMBH**

Wissmannstr, 59  
27755 Delmenhorst, Germany  
Tel. +49 4221 800 989-0  
info@faresin-nord.de

**FARESIN POLAND SP. Z O.O.**

ul. Borowiacka 9  
87-100 Torun, Polska  
Tel. +48 503 147 811  
poland@faresin.com

**FARESIN INDUSTRIES  
FRANCE**

2 Rue de l'Avenir 14460  
Colombelles, France  
Tel + 33 2 31 82 79 61  
france@faresin.com

It brings to the attention of all potential customers, all recipients, and to the maximum extent possible, external interlocutors, that Faresin Industries S.p.A. adopts a general Disclaimer regarding the description of the technical and functional characteristics of its machineries, as well as the manner of their use, also with regard to their safety. The Disclaimer must be understood as having a general scope, and therefore Faresin Industries s.p.a. invites to know it, also by accessing the website: [faresin.com](http://faresin.com)

**FARESIN.COM**



01.2025