

7.40 MIDDLE FS

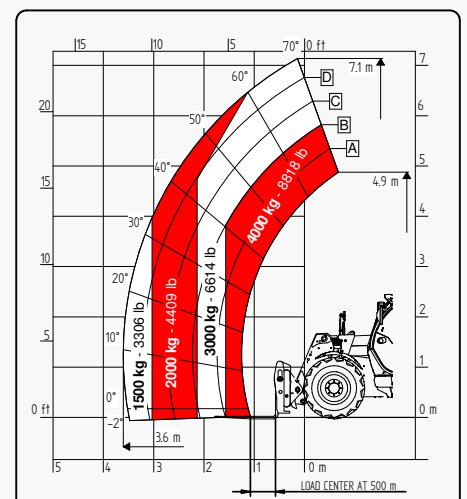

It brings to the attention of all potential customers, all recipients, and to the maximum extent possible, external interlocutors, that Faresin Industries S.p.A. adopts a general Disclaimer regarding the description of the technical and functional characteristics of its machineries, as well as the manner of their use, also with regard to their safety. The Disclaimer must be understood as having a general scope, and therefore Faresin Industries s.p.a. invites to know it, also by accessing the website: www.faresindustries.com

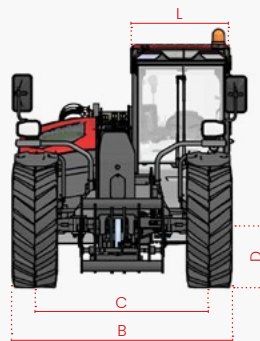
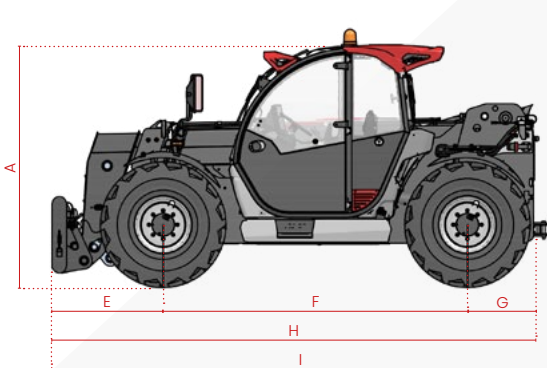

FARESIN.COM



7.40 MIDDLE FS

TECHNICAL FEATURES

MODELS		7.40
DIMENSIONS		
[A] Height	ft	8
[B] Width	ft	7.6
[C] Track	ft	6.1
[D] Ground clearance	ft	1.1
[E] Front overhang	ft	3.3
[F] Pitch	ft	9.7
[G] Rear overhang	ft	2.6
[H] Length without tow hook	ft	15.6
[I] Length with tow hook	ft	16.1
[L] Cab width	ft	3.1
WEIGHT		
CLASSIC 55	lbs	-
CLASSIC 75	lbs	-
DYNAMIC 85	lbs	-
PERFORMANCE 85	lbs	-
EXCELLENCE 85	lbs	-
EXCELLENCE HVTRONIC 100	lbs	-

MODELS		7.40
DETAILS		
Number of retracting sections	nr	1
Max flow rate	lbs	8,818
Max lifting height	ft	23.3
Horizontal max outreach	ft	11.8
Outreach at max height	ft	0.7
Swinging angle	°	144
TANK CAPACITY		
Hydraulic oil tank	gal	31.7
Diesel tank	gal	31.7

NOTE: Dimensions defined on Dynamic version with 20" wheels

● Standard ○ Optional - Not available

INSTALLATIONS		CLASSIC 55	CLASSIC 75	DYNAMIC 85	PERFORMANCE 85	EXCELLENCE 85	EXCELLENCE HVTRONIC 100
TRANSMISSION							
Hydrostatic		single gear	single gear	single gear	2 mechanical gears	2 mechanical gears	continuous variation
Speed	mph	15.5	18.6	18.6	25	25	25
ENGINE STAGE V							
Manufactured		Deutz	Deutz	Deutz	Deutz	Deutz	Deutz
Power	kW/hp	55,4/75	75/102	85/115	85/115	85/115	100/136
Post-treatment system		DOC + DPF	DOC + DPF + SCR	DOC + DPF + SCR	DOC + DPF + SCR	DOC + DPF + SCR	DOC + DPF + SCR
Pulling force	daN	5.100	5.100	5.100	5.890	5.890	10.000
HYDRAULICS							
Pump type		gears	gears	gears	LS piston	LS piston	LS piston
Distributor		flow sharing	flow sharing	flow sharing	flow sharing	flow sharing	flow sharing
Hydraulic flow-rate	gal/psi	26.4/3,625	26.4/3,625	31.7/3,625	39.6/3,625	44.9/3,625	44.9/3,625
WHEELS							
400/70 20		●	●	●	○	○	○
405/70 24		○	○	○	●	●	●
Steering radius	ft	13.1	13.1	13.1	13.6	13.6	13.6
VARIOUS							
Joystick		electro-hydraulic proportional	electro-hydraulic proportional	electro-hydraulic proportional	electro-hydraulic proportional	CAN-BUS electro proportional	CAN-BUS electro proportional
Quick coupling		○	○	○	○	●	●
Rear hydraulic connection		○	○	○	●	●	●
LED front lights		○	○	○	○	●	●
LED rear lights		●	●	●	●	●	●
LED front and rear work lights		○	○	○	●	●	●
Trailer lights rear socket		○	○	●	●	●	●
Fixed tow hook 12 t		○	○	●	●	●	●
Engine water preheating		○	○	○	○	○	○
Air conditioning		○	○	○	○	●	●
Ecofast Valve		N/D	N/D	N/D	●	●	●
Floating boom		○	○	○	○	●	●
Boom suspension		○	○	○	○	○	○
Manual 6-way diverter valve		○	○	○	○	●	●
BES (Boom Electric Socket)		○	○	○	○	○	○
Creeper		●	●	●	●	●	●
Constant front flow		●	●	●	●	●	●
Bucket mode		●	●	●	●	●	●
Radiator fan		proportional non-reversible	proportional non-reversible	proportional non-reversible	proportional reversible	proportional reversible	proportional reversible